

Application Note

1/22/12

Electric Fuel Pump Solution for Lycoming Engines

Background

Many Lycoming engines were originally manufactured without provision for a mechanical fuel pump. These engines were used primarily in high wing aircraft with a gravity feed fuel system supplying a carburetor.

This application note is intended to outline a dual electric fuel pump solution for Lycoming or other aircraft engine installations where a mechanical fuel pump can not be used or is not desired. In this case, a dual electric pump solution is required to offer the redundancy of a backup pump.

This note will cover the use of the EFII (www.flyefii.com) dual electric Fuel Pump Module, pn FPM-1 as the basis for this pump solution. The following fuel system layout is applicable to engines with a carburetor or mechanical fuel injection.

Fuel system layout

The solution outlined below is applicable to a two fuel tank airframe and will work in either high wing or low wing aircraft.

Reference DRAWING 1 on the following page.

Each wing tank feeds a duplex fuel valve. The fuel valve then feeds a 90 micron screen filter which in turn feeds the dual electric Fuel Pump Module. The output of the Fuel Pump Module goes through a T to feed both the engine and the fuel pressure regulator.

The fuel pressure of the system is controlled by the fuel pressure regulator. The regulator is a bypass type regulator which allows the pumps to flow with minimal restriction. Excess fuel that is not used by the engine is metered by the regulator so as to maintain the desired fuel pressure in the line feeding the engine. Excess fuel returns through the regulator, through the return section of the duplex valve and back to the selected fuel tank.

The Fuel Pump Module contains two electric fuel pumps. One pump is the primary pump, the other is the backup pump. The pumps are plumbed together via internal passages in the Fuel Pump Module manifolds for a clean, compact, and easy to mount system. Electrical power should be provided to the pumps via a 10A circuit breaker feeding a single pole, single throw, three terminal switch to select between the primary pump and the backup pump.

This is a simple and effective system that provides good pressure regulation, minimal stress on the fuel pumps and a redundant fuel source via the integral backup fuel pump.

Please note - All fuel system designs should be thoroughly checked and verified for proper design and function before being flown in an aircraft. This application note is meant as a guideline to assist aircraft builders. It is up the individual builder to verify that the fuel system design chosen for their aircraft is suitable and safe.

SAMPLE FUEL SYSTEM DUAL ELECTRIC PUMP SETUP

DRAWING 1

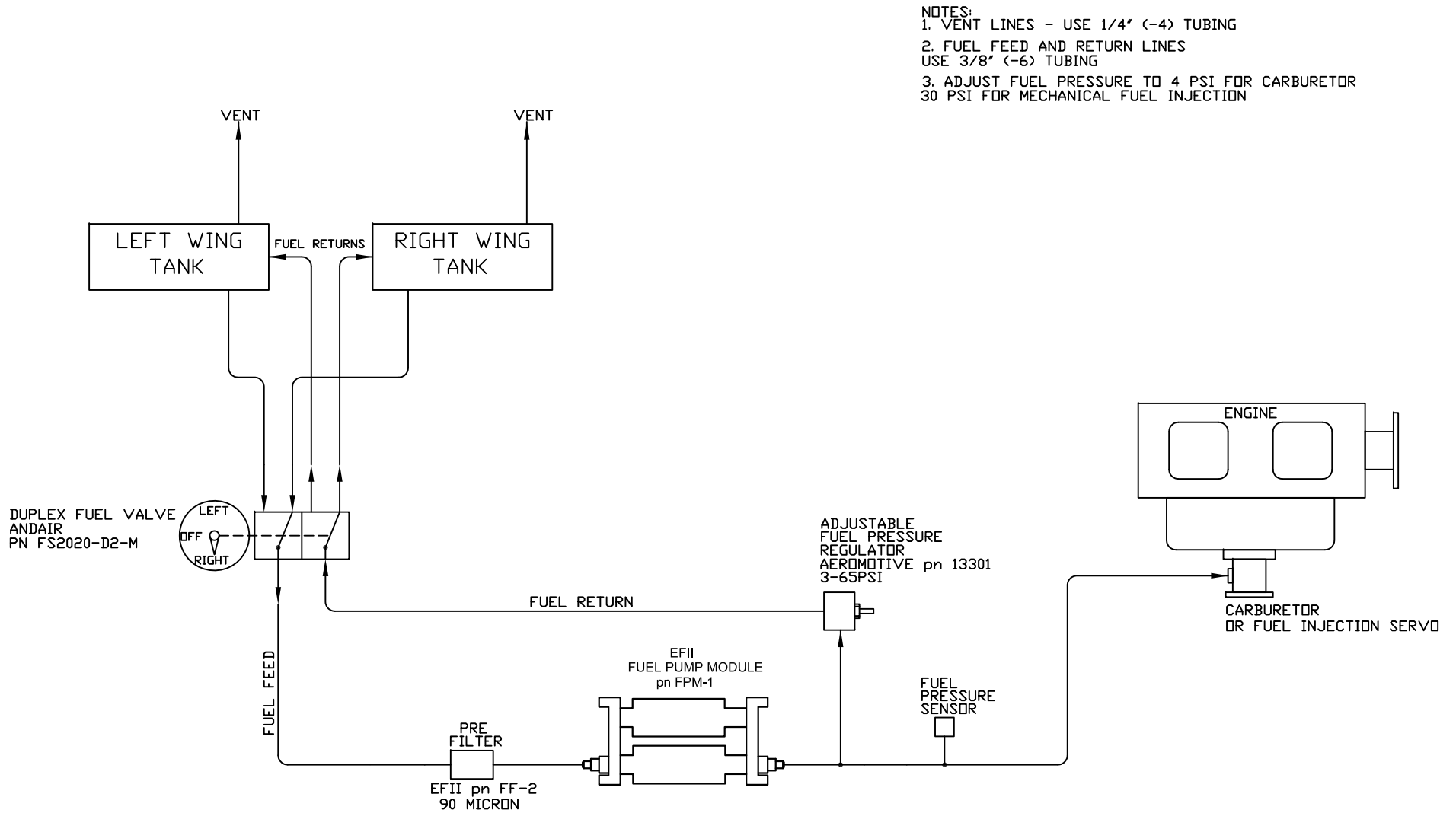

NOTES:

1. VENT LINES - USE 1/4" (-4) TUBING
2. FUEL FEED AND RETURN LINES
USE 3/8" (-6) TUBING
3. ADJUST FUEL PRESSURE TO 4 PSI FOR CARBURETOR
30 PSI FOR MECHANICAL FUEL INJECTION